

BG-301

INSTRUCTIONS



BIG GOOSE[®]

cool gadgets and stuff

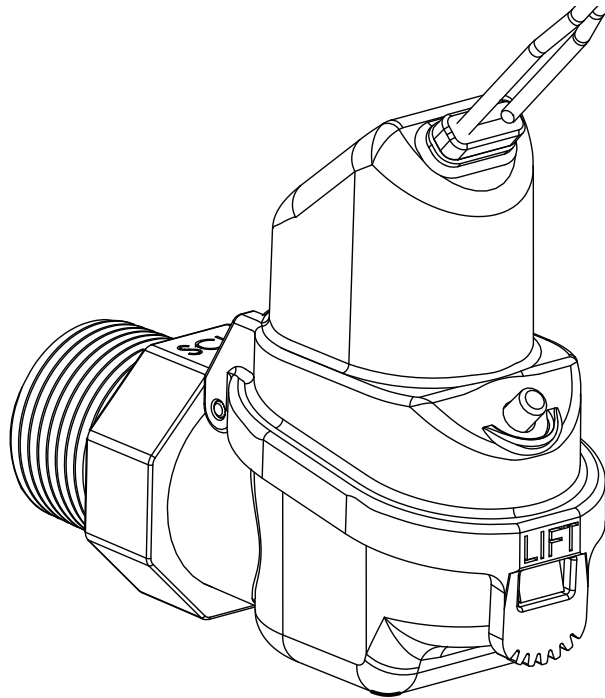

PRIMARY PAN SENSOR

Switch to measure and monitor the condensate water level on an HVAC unit.



WARNING WORK SAFE, READ THIS:

Failure to read and comply with all warnings, cautions, & instructions prior to starting installation may cause personal injury and/or property damage and will void warranty.

This device must be installed according to manufacturer's instructions, and must be in agreement with all applicable local HVAC, plumbing, drainage, and electrical codes.

Remove electric shock hazard - DISCONNECT THE POWER BEFORE INSTALLING SWITCH to avoid electrical shock and/or equipment damage. Do not use on circuits exceeding 24 volts to avoid damage to switch, shock, or fire hazard. Switch must be connected to an isolated transformer with a max rating of 30VAC, 8A, and 100VA.

In any installation where property damage may result from an inoperative switch due to power outage, a back-up system(s) and/or alarm should be installed.

The switch must only be installed by a licensed contractor or under the direct supervision of the same. The condensation pan must be properly maintained after installation and kept free from foreign objects, rust, or other obstructions that might interfere with the proper operation of the float switch.

WIRING THE BG-301 IN A CONVENTIONAL HVAC SYSTEM

(To ensure proper performance of product, instructions must be followed.)

1. Ensure the power is disconnected to the unit at the main panel prior to moving to the next step. Refer to the appliance manufacturer's installation and operating instructions and review wire layout in their instructions.
2. Locate the Red wire connecting the 24 Volt Transformer on the air handler and the Thermostat (See Fig 1).
3. Disconnect or cut.
4. Using Wire nuts, connect one of the Black wires of the BG-301 to the cable going to the 24 VAC transformer on the air handler.

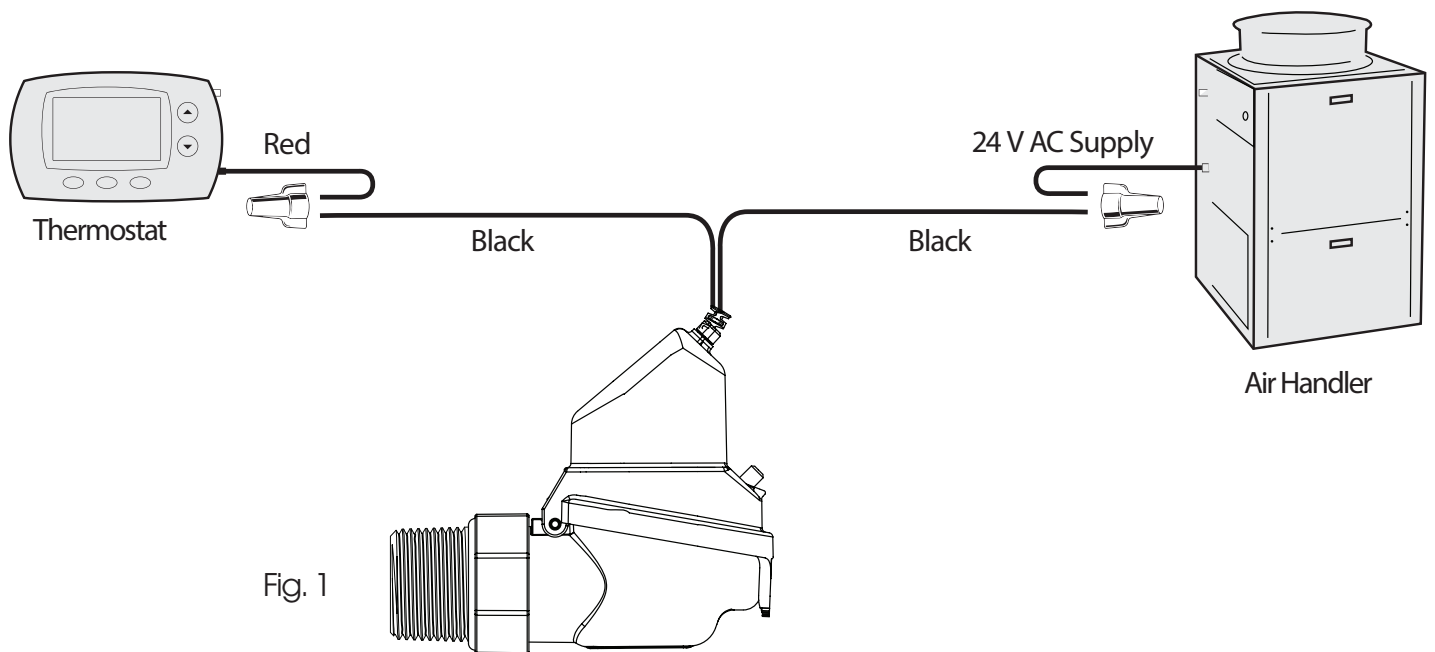

5. Using Wire nuts, connect the other Black wire of the BG-301 to the red wire going to the Thermostat. This configuration results in power to both air handler and compressor terminating when switch is tripped.

Note: If only compressor power is to be terminated, it is acceptable to connect to the yellow Thermostat wire as an alternate configuration.

The BG-101 is a normally closed switch. The switch is compatible with communicating HVAC systems. Please refer to your HVAC manufacturer for wiring instruction in communicating HVAC systems.

INSTALLATION OF FLOAT SWITCH ON DRAIN PAN

(To ensure proper performance of product, instructions must be followed.)

Disconnect power to unit at main panel. Disconnect power to the low voltage thermostat circuit.

Locate secondary condensate port on air handler.
(See Fig. 2)

Screw the pipe fitting provided with the BG-301 into the secondary port of the primary drain pan of the HVAC unit. Ensure a watertight seal by making sure the O-ring contacts the pan and seals the joint or use pipe tape on the threads to achieve a watertight seal.

INSTALLATION OF FLOAT SWITCH ON DRAIN PAN

(To ensure proper performance of product, instructions must be followed.)

1. Disconnect power to unit at main panel. Disconnect power to the low voltage thermostat circuit.
2. Locate secondary condensate port on air handler.
(See Fig. 2)
3. Screw the pipe fitting provided with the BG-301 into the secondary port of the primary drain pan of the HVAC unit. Ensure a watertight seal by making sure the O-ring contacts the pan and seals the joint or use pipe tape on the threads to achieve a watertight seal.

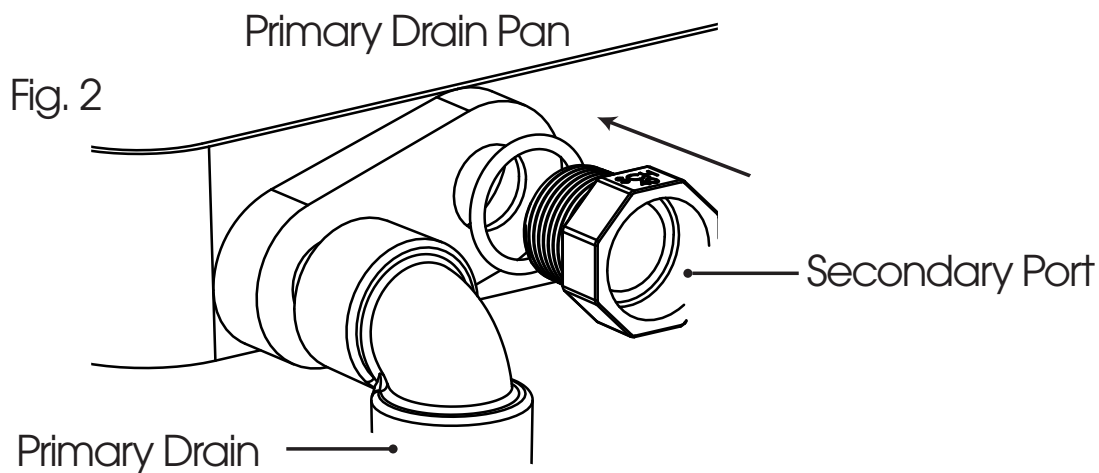

4. Attach BG-301 lower housing to fitting, ensuring it is not tilted to one side. (See Fig 3)

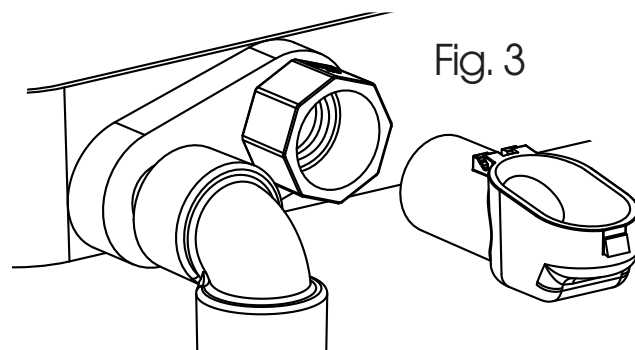

5. Mount top housing.
(Fig. 4)

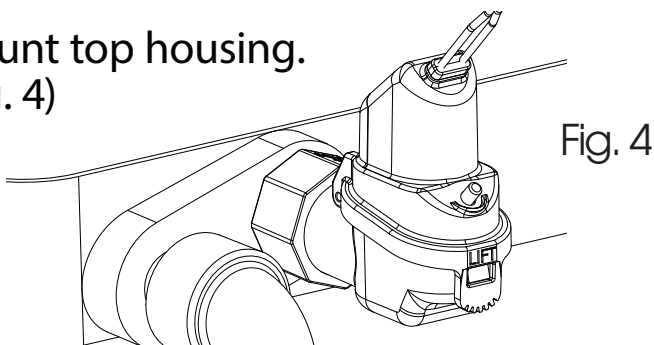

TEST THE BG 301 (REQUIRED BY WARRANTY)

1. TEST SWITCH OPERATION

- a. Open the cap by pulling outward and upward on the lift tab (See Fig. 5).

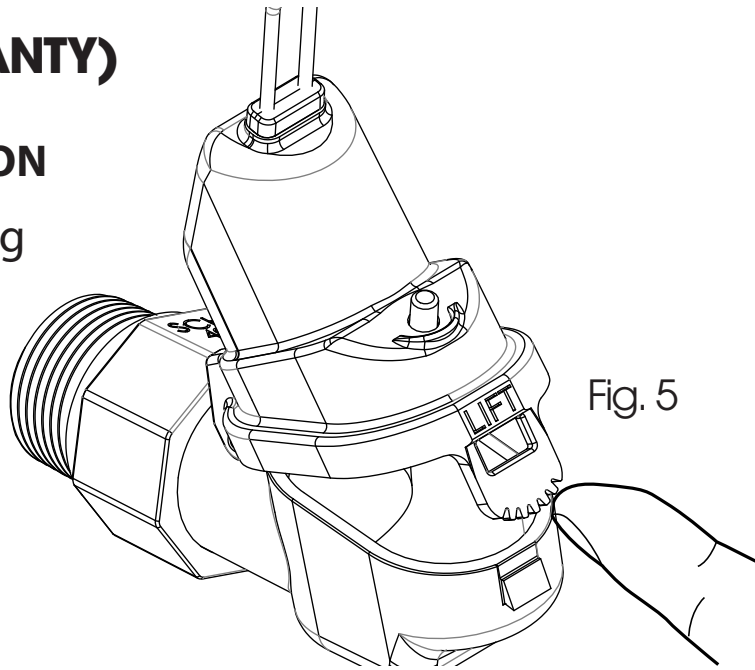

Fig. 5

- b. Gently turn to the right or left to remove cap (See Fig. 6).

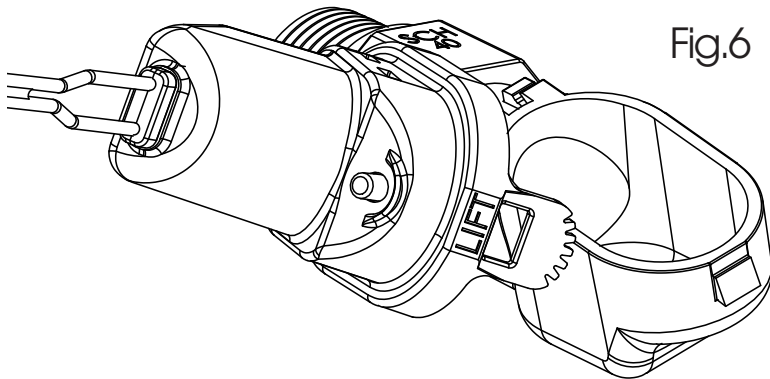

Fig.6

- c. Ensure Float is in lower position. HVAC Unit should be running.
- d. Lift the float (See Fig 7). HVAC unit should stop running if switch is correctly wired.
- e. Replace cap.

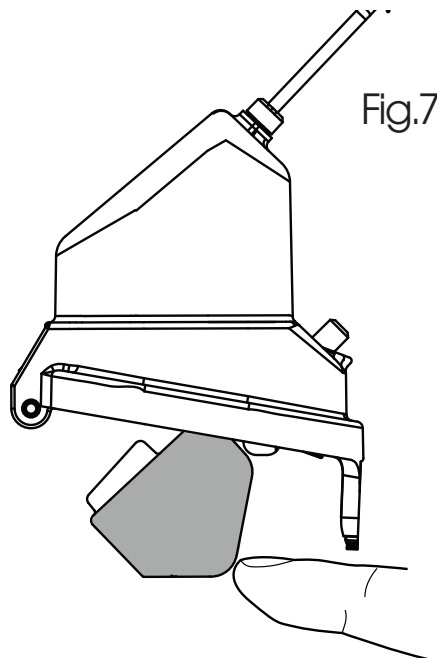
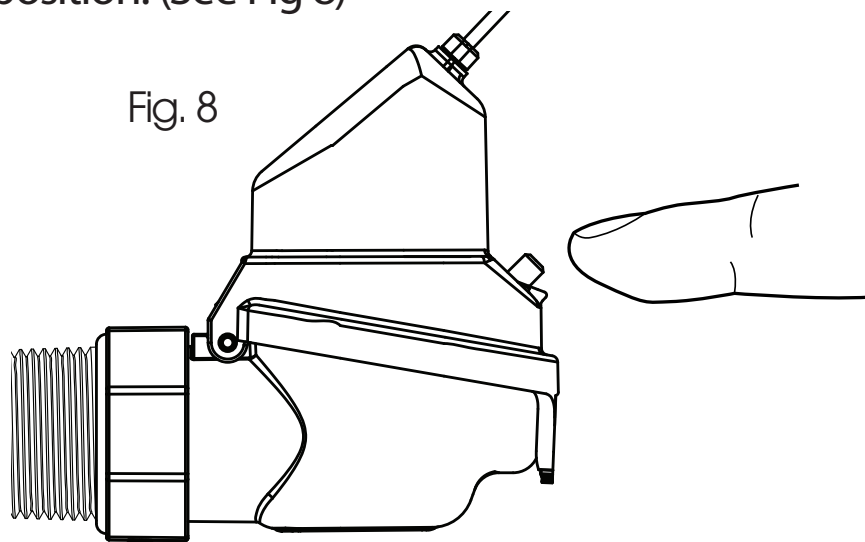

Fig.7

2. TEST SWITCH RESPONSIVNESS

- a. Press the Reset Button to ensure the float is in the lower position. (See Fig 8)



- b. Block drain downstream from installation point and run unit until pan is filled with water.
- c. Ensure that the switch snaps/latches and shuts down the unit before the pan overflows. Check for leaks.
- d. Ensure that the switch snaps/latches and shuts down the unit before the pan overflows. The RED indicator tab should be visible when the unit is tripped. (Fig 9)
- e. Check for leaks.

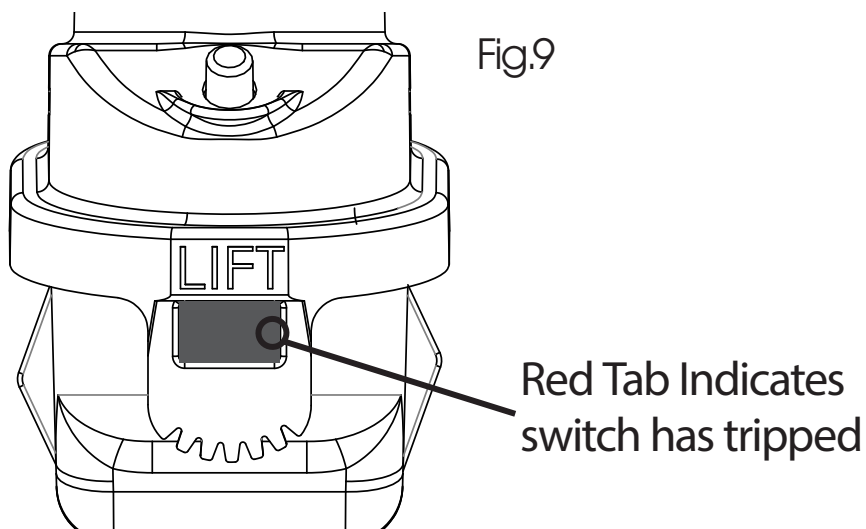

WARRANTY

Visit www.biggoose.com for warranty registration and information on BG-301

INSTRUCCIONES ESPANOL

Visite www.biggoose.com para instrucciones en espanol



BIG GOOSE®

Big Goose LLC
P.O. Box 1298
Bradenton, FL 34206



LISTED
Ind. Cont. Eq
4LJ2